

# HIAB 033 T Capacity 3.3 tm

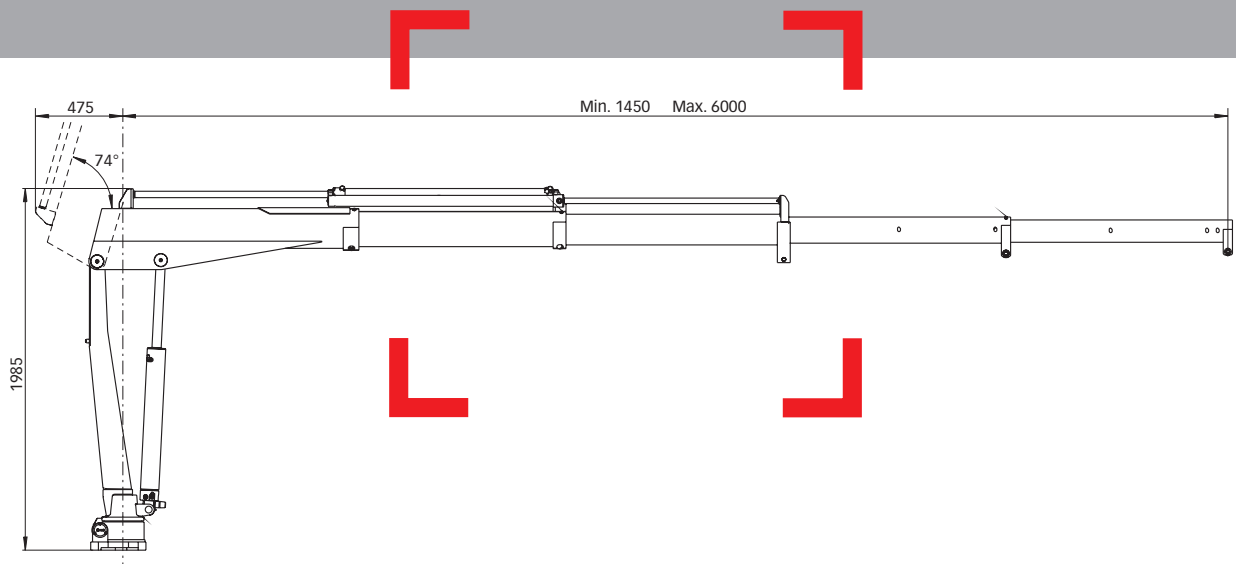

Basic data

# HIAB 033 T Basic data

## Technical data

	033 T-2	033 T-3
Max. lifting capacity (kNm)	32.8	31.7
Outreach - hydraulic extensions (m)	3.6	4.8
Outreach - manual extensions (m)	6.0	6.0
Outreach / lifting capacity (m / kg)	1.4 / 2470	1.5 / 2310
	2.4 / 1400	2.5 / 1330
	3.6 / 930	3.7 / 880
	-	4.8 / 670
Slewing angle	330°	330°
Height in folded position (mm)	1630	1630
Width in folded position (mm)	750	750
Installation space needed (mm)	-	-
Weight - "standard" crane without stabilizers (kg)	295	335
Weight - stabilizer equipment (kg)	12 - 20	12 - 20

## HIAB 033 T-3

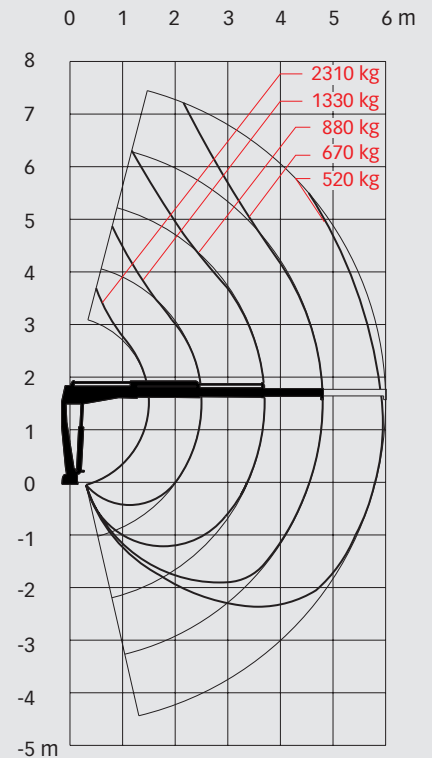
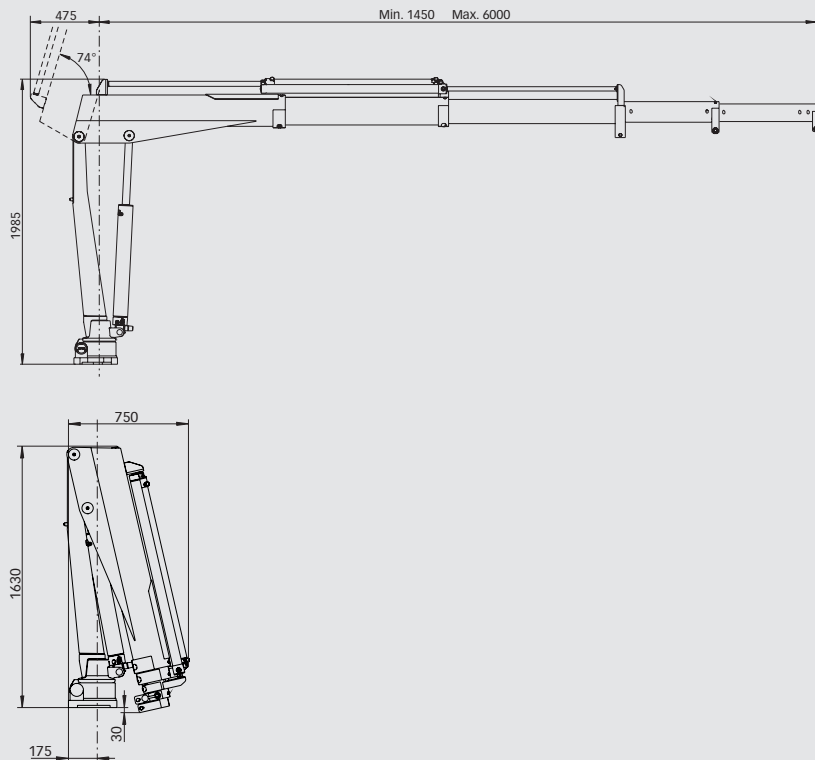

### Disclaimer

Hiab cranes has been built to meet the highest standards of safety and service life and has been thoroughly tested. Strength calculations for this model have been carried out in accordance with DIN 15018. Hiab's certified Quality Assurance System complies with the ISO 9001. Some of the items in our literature may be extra equipment. Certain applications may require an official permit. We reserve the right to change technical specifications without prior notice. Hiab cranes produced for EU-countries are CE-marked and comply with the European Standard EN 12999.